

GENERATED FROM P/N:

REVISIONS			DATE	CHG	CHK
ECN	ZONE	LTR	DESCRIPTION		
~					

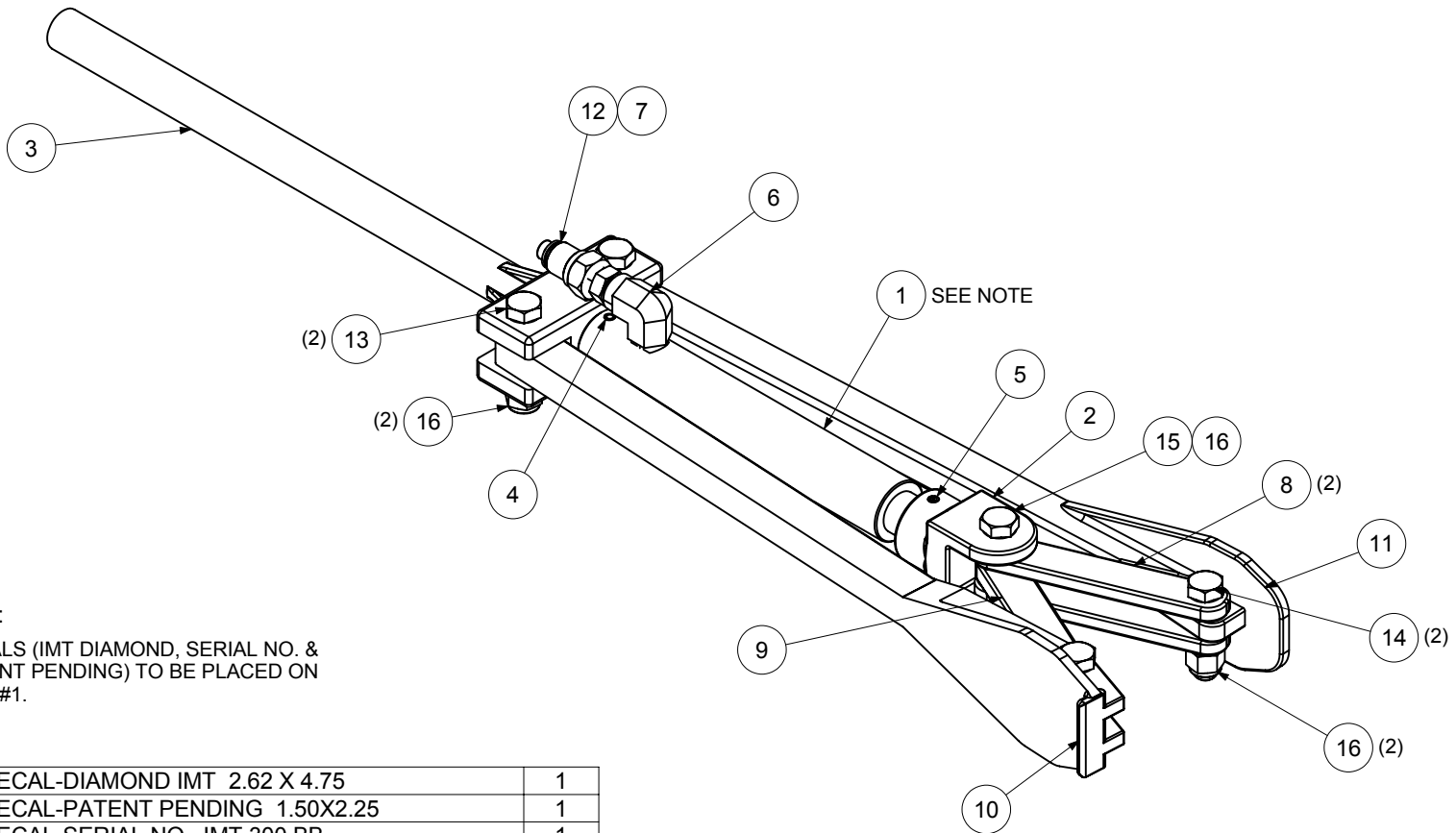

NOTE:

DECALS (IMT DIAMOND, SERIAL NO. & PATENT PENDING) TO BE PLACED ON ITEM #1.

19	70391456	DECAL-DIAMOND IMT 2.62 X 4.75	1
18	70392311	DECAL-PATENT PENDING 1.50X2.25	1
17	70392307	DECAL-SERIAL NO. IMT 300 BB	1
16	72062080	NUT .50-13 HEX NYLOCK	5
15	72601369	CAP SCR .50-13X 3.00 HH GR8 Z	1
14	72601368	CAP SCR .50-13X 2.25 HH GR8 Z	2
13	72601296	CAP SCR .50-13X 2.50 HH GR8 Z	2
12	72053546	NIPPLE-DISC .38FPT 10,000 PSI	1
11	70142760	ARM-DUAL BEAD BREAKER (FLAT)	1
10	70142724	ARM-DUAL BEAD BREAKER (W-LIP)	1
9	70142727	PIVOT ARM-IMT 300 BEAD BREAKER .50	1
8	70142726	PIVOT ARM-IMT 300 BEAD BREAKER .38	2
7	72053723	ADPTR-MPT/HEX/MPT .38 .38	1
6	72531132	ELBOW-STREET STL .38 X 90 DEG	1
5	72066734	ROLL PIN .25X1.75	1
4	72066318	ROLL PIN .25X1.50	1
3	70142723	HANDLE-IMT 300 BEAD BREAKER	1
2	70142725	CLEVIS-IMT 300 BEAD BREAKER	1
1	70731611	RAM-IMT 300 BEAD BREAKER	1

ITEM	PART NUMBER	DESCRIPTION	QTY
Parts List			

THIS DRAWING IS THE PROPERTY OF IOWA MOLD TOOLING CO., INC. TRANSMITTED IN CONFIDENCE, AND THE REPRODUCTION, USE OR DISCLOSURE, IN WHOLE OR IN PART, OF THE DESIGN AND DETAILS CONTAINED HEREIN IS PROHIBITED WITHOUT THE WRITTEN PERMISSION OF IOWA MOLD TOOLING CO., INC.

AutoCAD Inventor
GENERATED
DRAWING

PRODUCT NO. BEAD BREAKER

UNLESS OTHERWISE SPECIFIED:
DIMENSIONS ARE IN INCHES.
TOLERANCES
UNLESS OTHERWISE SPECIFIED:
ANGLE 1
FRACTION 1/16
DECIMAL .XX .060
DECIMAL .XXX .010
DECIMAL .XXXX .005

MATERIAL	
DRAWN BY palmiejm	DATE 12/14/2007
CHECKER	DATE
MFG. ENGR. APPROVAL	
DESIGN APPROVAL	

		IOWA MOLD TOOLING CO., INC. 500 HWY 18 WEST GARNER, IOWA 50438	
TITLE BEAD BREAKER-IMT 300			
SIZE C	CAGE CODE	DWG NO. 51705003	
SCALE 1:2	UNIT WT. 23.0#	SHEET 1 OF 1	