

SINGLE BEND SWIVEL VALVES

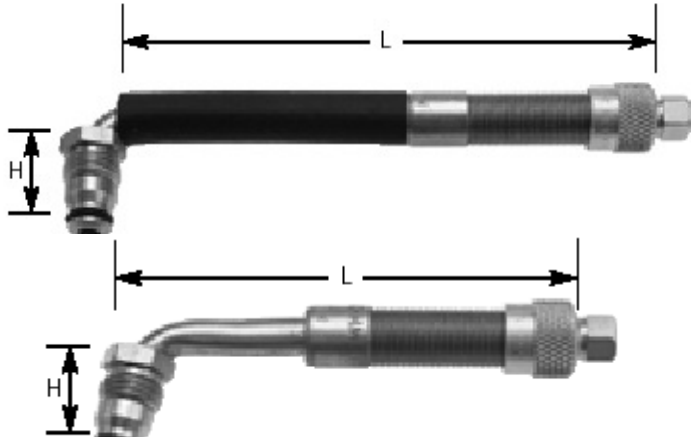

Part Number	TR #	Bend Angle	"L" Length	"H" Height
WH300-J650	J650	80*	3-1/8"	1-5/64"
WH45-2-1/2	J4000	90*	2-1/2"	1-5/64"
WH45-4-1/2	J4000	90*	4-1/2"	1-5/64"
WH45-7-1/2	J4000	90*	7-1/2"	1-5/64"
WH45-9	J4000	90*	9"	1-5/64"
WH46-J651	J651	90*	4-11/16"	1-5/64"
WH49-J654	J654	90*	3-1/8"	1-5/64"
WH50-J660	J660	90*	8-3/4"	1-5/64"

TUBELESS SPUD



Part#
H41

Fits 13/16" rim hole. Used with all Large Bore swivel valves

Description
Tubeless Spud

STRAIGHT VALVE



Part#
H42

Straight valve, equipped with core and hex cap.

TR#
TRJ670-2

Height
1-1/2"

LOADER TIRE VALVE



Part#
T670

Loader tire valve complete with core, hex cap and O-ring seal. Thread size is 11/16-12.

Description
Loader Tire Valve

EXTENSIONS



Hand-Bendable

Equipped with 2 lock nuts and 3/4" hex sealing nut. A teflon gasket seals on end of valve, the lead seal in the sealing nut is forced into the threads for a second seal, positively locking extension to valve. Cap and core not included. They should be removed from valve and transferred to extension. Should be anchored to rim.

Part Number	Effective Length
753S-4-1/2	4-1/2"
753S-8	8"
73S-9	9"
753S-10	10"
753S-16	16"
753S-18	18"
753S-24-1/2	24-1/2"

LARGE BORE SCREW-ON VALVES FOR INNER TUBES

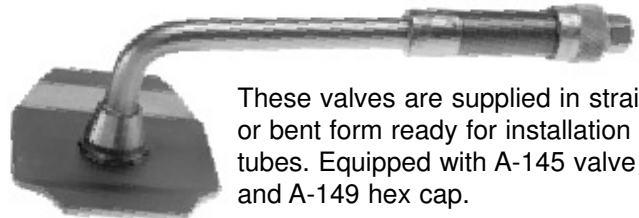

These valves are supplied in straight or bent form ready for installation on tubes. Equipped with A-145 valve core and A-149 hex cap.

Part Number	TR #	Angle Bend	Vert. Height	Horiz. Length
LB216	J1014	Straight	1-29/32"	
LB220	J1076D	90*	2-1/16"	2-5/16"
LB225	J1175C	88*	1-3/8"	4-1/8"

SUPER LARGE BORE AIR LIQUID VALVE FOR TRACTOR & GRADER



Part#
H50
R372

Components
T-81 spud
and R-372
core housing.

Description
Straight Valve Assembly
Core Housing



LARGE BORE

O-RINGS FOR TUBELESS RIMS



Packaged 2 per poly bag. 24 O-rings per case O-rings individually marked in an easy to read color.

Part Number	Tire Type	Rim Size
OR20JM	Highway	20"
OR22JM	Highway	22"
OR24JM	Highway	24"
OR25T	Earthmover	25"
OR88TX	Grader	24"
OR220TG	Grader	20"
OR224TG	Grader	24"
OR232TG	Tractor	32"
OR321T	Earthmover	21"
OR325T	Earthmover	25"
OR329T	Earthmover	29"
OR333T	Earthmover	33"
OR335T	Earthmover	35"
OR339T	Earthmover	39"
OR343T	Earthmover	43"
OR345T	Earthmover	45"
OR349T	Earthmover	49"
OR457T	Earthmover	57"

LARGE BORE CORES & CAPS



A145



A144



A149

Part#	Description
A145	Large Bore Core (short)
A144	Large Bore Core (long)
A149	Hex Large Bore Valve Cap

LARGE BORE GAUGES



Nickel-plated brass Metal slide bar. Easy to read. Calibrated 10-150 in 2 lb. units. Swivels 360° for those hard-to-reach valves.

Part#	Description
GA255S	Large Bore Swivel Ft Gauge

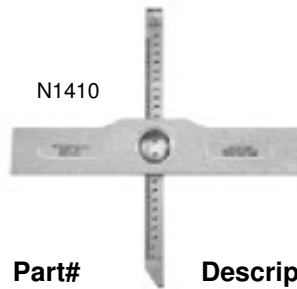

N1410

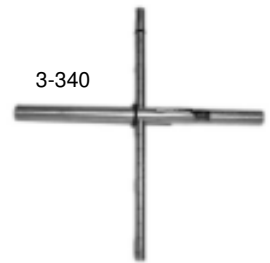

3-340

Part#	Description
N1410	Off Highway Tire Tread Depth Gauge Deluxe, with magnified sight glass. With carrying holster.
3-340	Pocket Tractor Tread Depth

VALVE ADAPTERS



8807N4



3007

Adapts Large Bore valve down to Standard Bore. Fits in 305-32 valve core threads. Adapts Large Bore valve down to Standard Bore. Fits on .485-26 valve cap threads.

Part#	Description
8807N4	Valve Adapter
3007	Valve Adapter

LARGE BORE TOOLS



1477



ASP10



TL690/695

Part#	Description
1477	Large Bore 4-way Valve Tool
ASP10	Large Bore Tube Deflator
TL690	Large Bore Core Tool
TL695	Lg Bore/Air Wtr Valve Tool



LARGE BORE CORE TOOL



Part#	Description
N1910	Large Bore Core Remover 6" Plastic Handle

IMPLEMENT VALVE



Low-profile valve offers minimum protrusion above the rim. 9/16" effective length with chromefinish. Fits .453 or .625 valve hole.

Part#	Description
6008A	Implement Valve Stem

LARGE BORE AIR CHUCKS

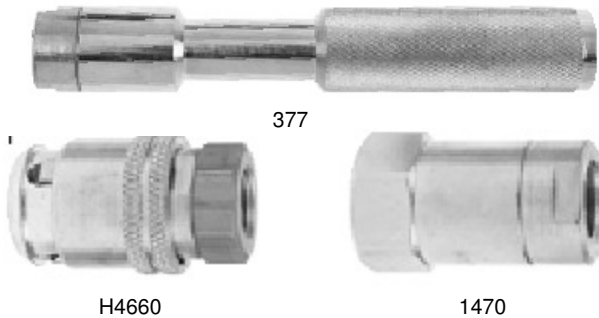

#377 Chuck locks on valve when cocked on threads. Has greater air flow and seat cannot be blown out if seal fails. Has 1/4" NPT female thread.

#1470 Chuck locks on valve when cocked on threads. Has greater air flow and seat cannot be blown out if seal fails. Has 1/4" NPT.

#H4660 Securely locks onto valve when sleeve is pushed forward, releases when sleeve is pulled back. Has 1/4" NPT

Part#	Description
377	Lock on L/B Air Chuck
H4660A	Large Bore Core (long)
1470	Hex Large Bore Valve Cap

AIR LIQUID EXTENSION

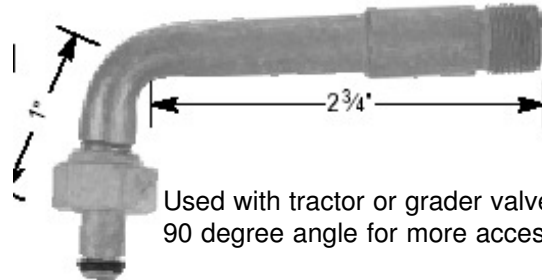

Used with tractor or grader valve stems. 90 degree angle for more accessible valve.

Part#	Description
TV5905	Air/Liquid Extension

CORE HOUSINGS



Part#	Description
S465	Old style core housing
17-587	CH3 Core Housing

AIR LIQUID VALVES FOR TRACTORS AND ROAD GRADERS

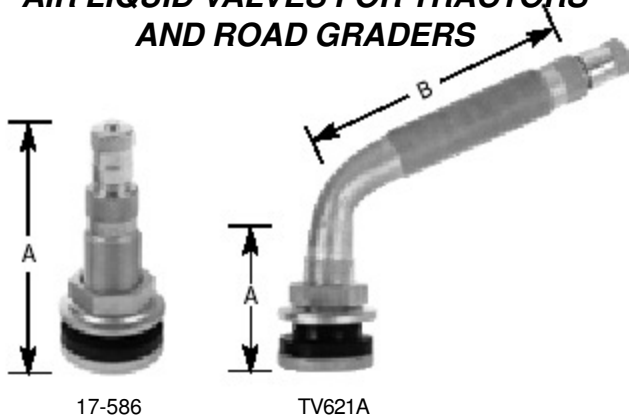

Part Number	TR #	A	B	Valve Hole
17-586	TR618A	1-7/8"	-----	.625
TV621A	TR621A	1-1/2"	3"	.625

RIM HOLE PLUGS



Part#	Description
N1012S	Metal 5/8" Rim Hole Plug
P15	Rubber 5/8" Rim Hole Plug

RIM NUTS & BUSHINGS

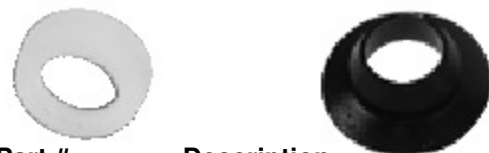

Part #	Description
LN10	Rim Nut for tractor valves
LN10P	Plastic Rim Nut for Tractor tube valves
17-588	Fits over TR13 tube valve when used in 5/8" valve hole (100 bx)